

# Astor CTM3 Manual Wall Mounted Changing & Showering Stretcher



## Highlights:

- Bespoke lengths available
- 150 kg SWL
- Compact - protrudes just 180 mm when stowed
- Suitable for use in wet-rooms

The Astor CTM3 is a manual height adjustable changing stretcher, ideal for the situations where an electric supply is not available, or, at around half the price of an electric powered version, as a cost effective option. It is also a compact option, protruding just 180mm from the wall when stowed.

The Astor CTM3 manual changing bench can safely be used in wet, dry and humid environments and is available in stretcher sizes from 1200 mm to 1900 mm x 720 mm with non-standard sizes available on request. This piece of specialist equipment has a wide range of optional extras for added safety and comfort such as a fold out guard and protective bumper as well as splash skirts for showering and a removable mattress for added comfort.



## Standard Features:

- Choice of stretcher lengths: 1200 mm-1900 mm
- MWL 150 kg/ 24 st
- 300 mm height range
- Protrudes just 180mm from wall when stowed
- Suitable for use in wet rooms with stainless steel frame
- Durable non-rip high tension vinyl hammock stretcher
  - anti-microbe treated and fully drainable
- 3 Year warranty (*Terms and conditions apply*)

## Optional Extras:

- Foldaway guard
- Protective padded guard bumper
- Anti-splash skirt
- Supports and cushions
- Removable mattress



# Product Specification Sheet:

## Astor CTM3 Changing & Showering Stretcher







<b>Model Name:</b>	Astor CTM3
<b>Product Description</b>	Manual wall mounted changing & showering stretcher
<b>Product Codes</b>	00.137.10.xxxx 00.137.10.1200 - 00.137.10.1900 (1200mm - 1900mm)
<b>Mattress Size</b>	1200 mm - 1900 mm x 720 mm
<b>Height Range</b>	300 mm (can be wall mounted at a height to suit)

### Features:

				
Height Adjustable	Manual Operation	Hoist Compatible	150kg MWL	3 Year Warranty

### Options:

				
1200 - 1900mm	Fold Away Guard	Bumpers & Cushions	Service Packages	Many More Options

### Application:

			
Private Home	School	Leisure Centre	Respite Home

### Technical Drawings:

All dimensions in mm:

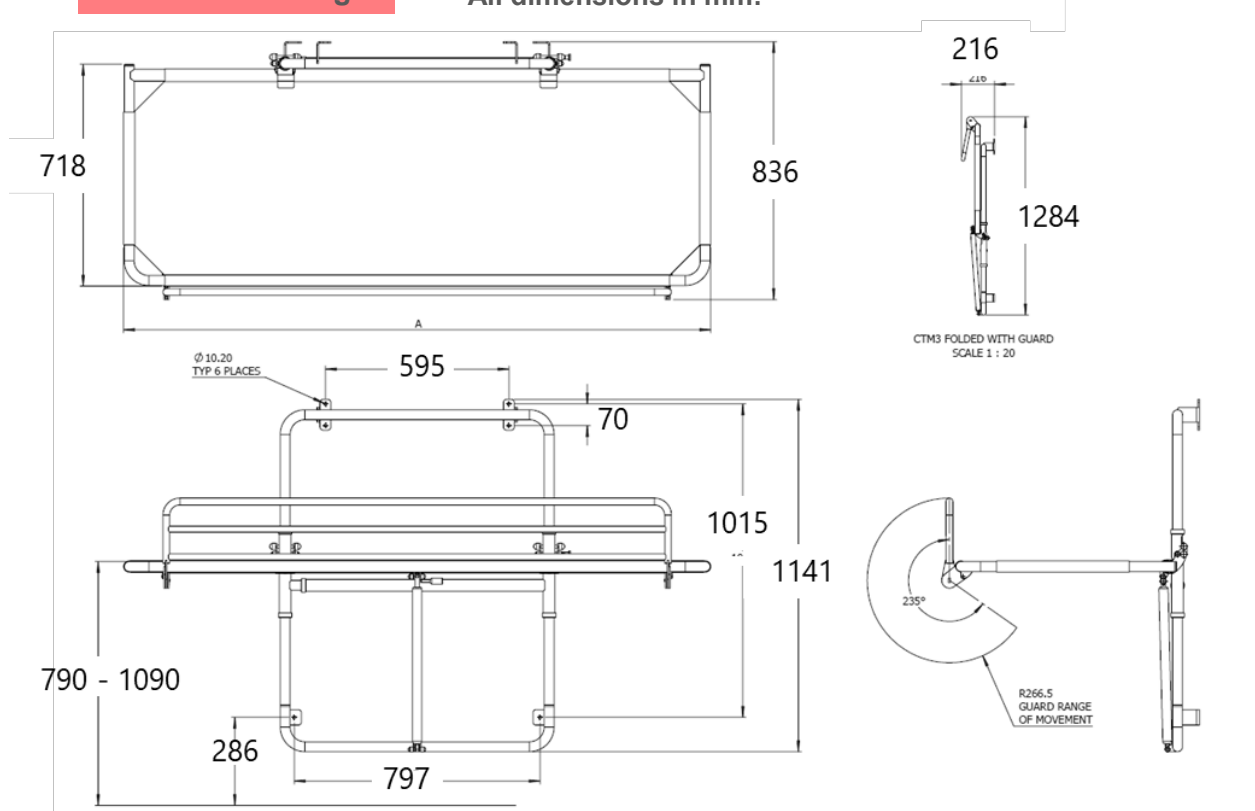

**Astor Bannerman**, Andoversford Link, Cheltenham GL54 4LB  
 sales@astorbannerman.co.uk  
**01242 820820**  
 www.astorbannerman.co.uk

CTM3 SS Rev 4 03/23